

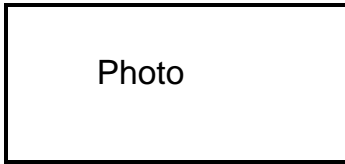

Design Release
Gear series GB U
 Spur Reduction Gearhead -60 Kg-cm



Design

Gearhead GB U contains heavily loaded steel gear wheels. The spur gears are fixed on steel spindles which are hardened and polished to a mirror finish & rotate in robust sintered bushings. The thick output shaft rotates in robust brass bushings. All the gears are housed in between metal plates & closed by plastic dust cover. All bearings are permanently lubricated and therefore require no maintenance. GB V can also be combined with small to medium sizes of DC motors (up to $\phi 52\text{mm}$).

Standard data

Gear torque	kg-cm	60
Combination with Mechtex Motors		MT0, MT6, MTR/S5, MTR/S-4a/b, MTR/SD-4, MTR/SD4-RE & DC motors (Up to dia 52) MTR/SD 7a, MTR/S 8c, MTR/S D8c MTR9a,b,c,d
Mounting		any position
Weight	gm	250
Axial thrust	kg	3
Radial torque	kg	40
Lateral force	kg-cm	10
Output Bearing		Brass
Ambient temperature operation	$^{\circ}\text{C}$	-15 ... +55
Output shafts		dia. 8 x 22 mm (with a flat); others on request
Ambient temperature operation	$^{\circ}\text{C}$	-15 ... +55

Transmission ratios

2,3,4,25/6,5,25/3, 10, 15, 50/3, 20, 25, 30, 100/3, 75/2, 40, 125/3, 50, 60, 200/3, 75, 250/3, 375/4, 100, 120, 125, 400/3, 150, 500/3, 180, 375/2, 200, 225, 250, 300, 1000/3, 375, 450, 500, 600, higher ratios on special request

Dimensional Drawing

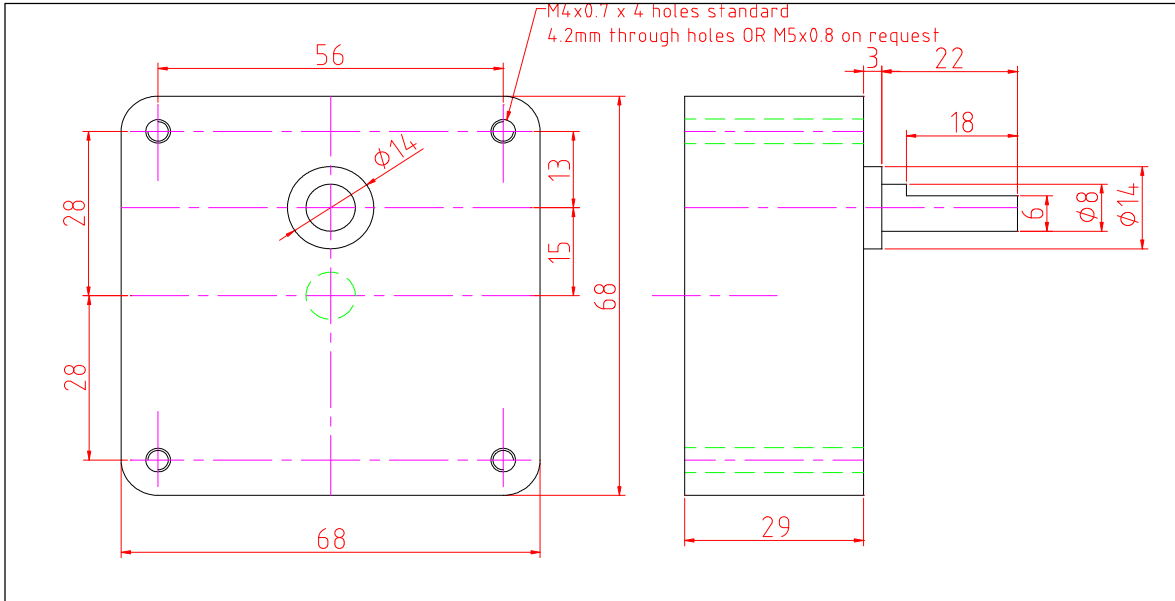

Torque/ Transmission Ratios/ Life Graph

